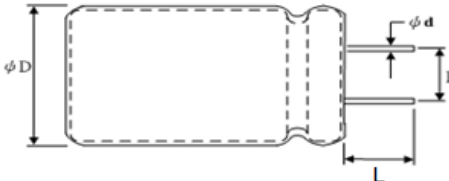
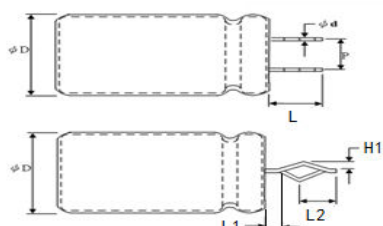
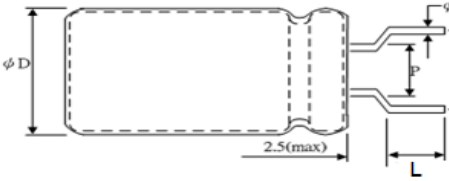
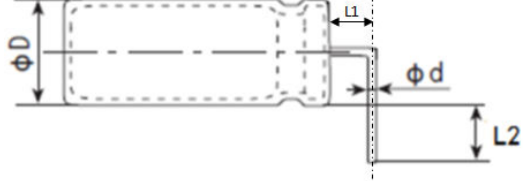

引线型加工规格：

<p>形状</p> <p>代码C*/P*：直切短脚型</p> 	<p>适用尺寸</p> <p>ΦD=4~18</p>	<p>形状</p> <p>代码K*：波浪切脚 & 曲卷型</p> 	<p>适用尺寸</p> <p>ΦD=4~18</p>
<p>代码F*：成型截断型</p> 	<p>适用尺寸</p> <p>ΦD=4~8</p>	<p>代码V*/O*/Z*/X*：卧式加工</p> 	<p>适用尺寸</p> <p>ΦD=4~18</p>

单位：mm

C	代码	1	2	3	4	5	6	7	8	9	A	B	C	D	E	F	G	H
	L	2.5	2.8	3.2	3.4	4.0	4.5	5.0	5.5	6.5	7.0	8.0	10.0	3.6	6.0	3.2	4.2	2.4
	代码	J	K	L	M	N	P	Q	R	S	T	U	V	X	Y	Z	W	
	L	4.2	3.7	12.0	2.0	2.2	2.5	13.5	9.0	20.0	16.0	18.0	3.0	13.0	12.5	15.0	3.1	

P	代码	1	2	3
	L	11.0	3.8	14.0

K	代码	1	2	3	4	5	6	7	9
	L	3.2	4.5	5.0	3.5	4.0	4.3	3.5	3.2
	代码	A	B	D	E	F	H	K	L
	L	3.3	3.6	3.6	3.3	18.0	7.0	6.8	4.0

X	代码	3
	L1	1.8±0.2
	L2	3.0±0.2

F	代码	1	2	3	4	5	6	7	8	9	A	B	C	D	E	F	G	H
	L	3.0	3.1	3.2	3.4	3.5	4.0	4.8	4.5	3.2	6.0	4.3	5.0	3.0	3.6	5.0	3.0	6.5
	代码	J	K	L	M	N	O	P	Q	R	S	T	U	V	W	Z	I	
	L	3.7	2.5	2.2	1.5	2.9	3.7	7.0	4.2	9.0	2.8	3.7	2.4	4.0	3.1	4.5	4.0	

V	代码	1	2	6	J	Q	F	8	N
	L1	1.25±0.25	2.5±0.5	2.5±0.25	1.0±0.5	1.5±0.5	1.25±0.25	2.0±0.5	2.2±0.5
	L2	2.6±0.3	3.5±0.5	4.1±0.5	3.85±0.25	3.0±0.5	11.5±0.5	4.0±0.5	<3.6
	代码	5	P	3	Y	R	G	9	Z
	L1	2.5±0.25	5.0±0.5	2.5±0.25	1.0±0.5	1.5±0.5	1.0±0.2	2.0±0.5	2.2±0.5
	L2	3.25±0.25	3.25±0.25	4.1±0.5	3.85±0.25	3.0±0.5	2.4±0.3	4.0±0.5	<3.6
	代码	B	S	U	H	D	O	E	M
	L1	2.5±0.5	2.0±0.5	3.5±0.3	1.0±0.2	2.0±0.5	2.5±0.5	1.5±0.2	3.3±0.2
	L2	3.3±0.5	3.5±0.3	5.0 +0,-0.5	2.4±0.3	6.7±0.5	7.0±0.5	2.25±0.25	3.25±0.25
	代码	X	W	V	7	C	A	4(不剪脚)	T
	L1	2.5±0.5	2.0±0.5	1.0±0.5	2.0±0.5	1.6以下(含拍d)	2.5±0.3	4.0±0.5	2.0以下
	L2	5.8±0.5	2.5±0.5	3.5±0.3	3.2±0.4	2.0±0.5	3.7±0.3	15.5±0.5	9.3±0.5

O	代码	1	2	5	8	B	G	H	M
	L1	2.0±0.3	1.±0.2	1.2±0.25	1.0±0.3	1.5±0.5	1.5±0.5	1.5±0.5	3.0±0.5
	L2	3.7±0.3	3.7±0.3	2.0±0.2	2.3±0.2	6.5±0.2	3.2±0.2	5.0±0.2	6.0±0.5

Z	代码	3	C	I	U	4	6	7	8
	L1	2.0+0/0.5	2.5±0.5	1.0±.2	1.2±.2	2.5±0.5	1.0±0.2	4.0±.5	2.5±0.3
	L2	3.85±0.25	4.6±.5	3.0±.2	2.8±.3	3.85±0.25	3.80±0.2	3.4±0.5	3.5±.3

备注：以上尺寸如无所需要尺寸请与本司联系。

焊针型加工规格：

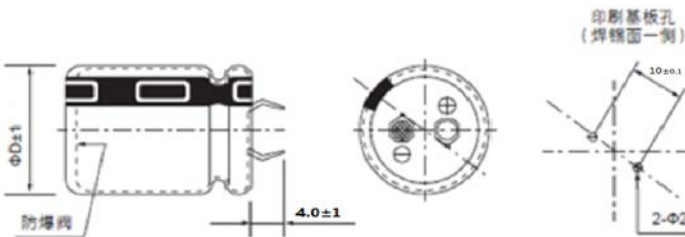
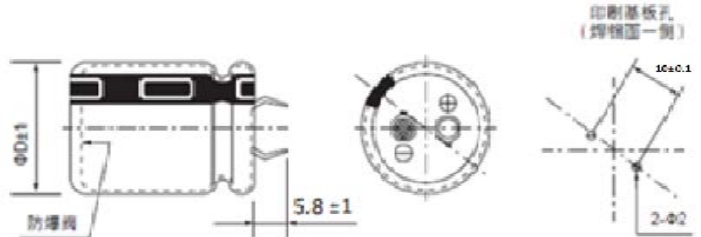
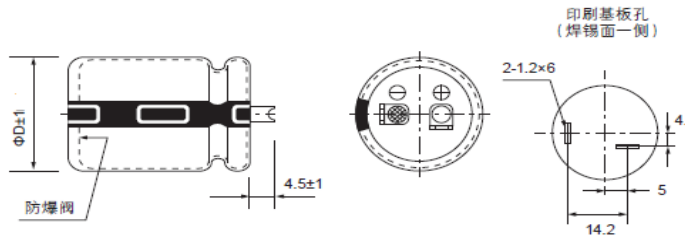
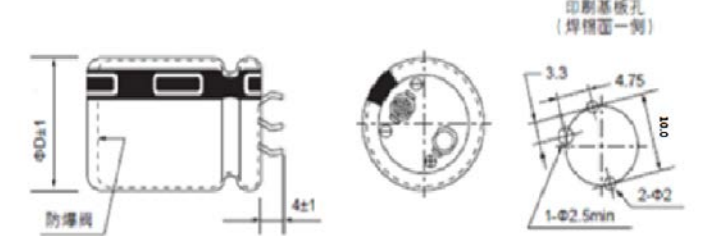
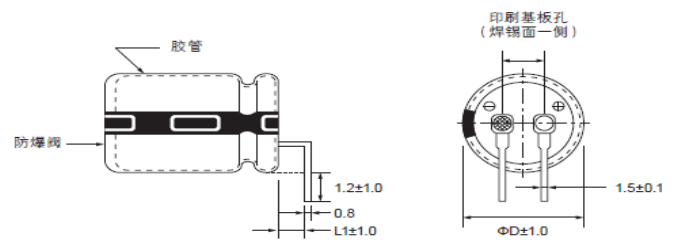
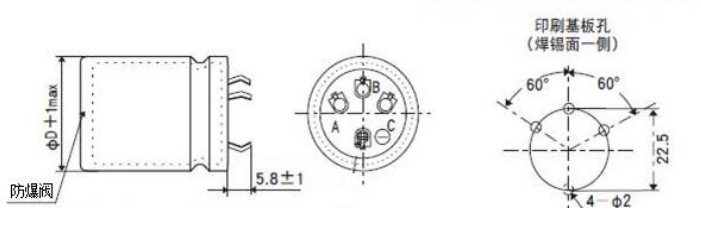
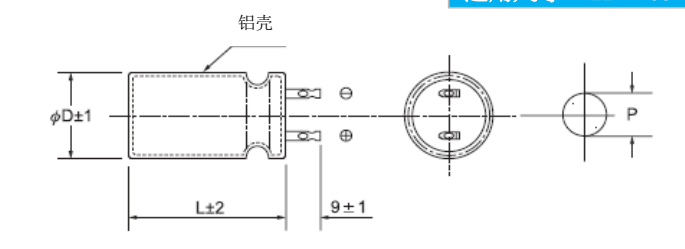
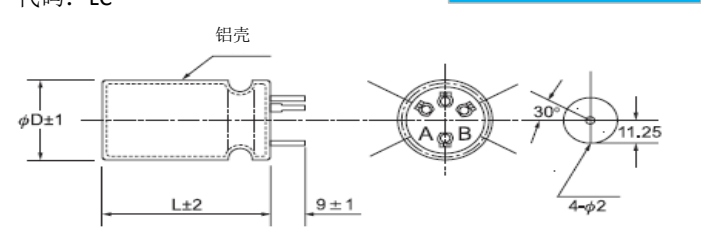
<p>标准品代码：S1(第13码为G) 适用尺寸 $\Phi 22\sim\Phi 35$</p> 	<p>标准品代码：S1(第13码为A) 适用尺寸 $\Phi 22\sim\Phi 35$</p> 
<p>代码：LL 适用尺寸 $\Phi 25\sim\Phi 40$</p> 	<p>三端子代码：L3 适用尺寸 $\Phi 25\sim\Phi 35$</p> 
<p>卧式代码：V3 适用尺寸 $\Phi 22\sim\Phi 35$</p> 	<p>四端子代码：L4 适用尺寸 $\Phi 35\sim\Phi 45$</p> 
<p>代码：LT 适用尺寸 $\Phi 22\sim\Phi 35$</p> 	<p>代码：LC 适用尺寸 $\Phi 35\sim\Phi 45$</p> 

螺栓型加工规格：

标准品代码：A1

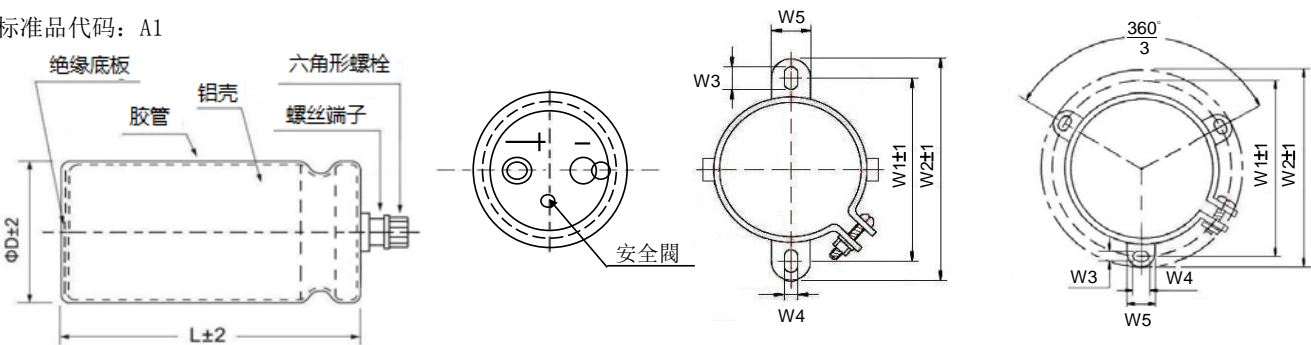

ϕD	W1	W2	W3	W4	W5
35	48.0	58.0	6.0	3.5	10
51	63.5	73.0	5.0	7.0	14
64	76.2	85.1	5.0	7.0	14
77	88.9	98.4	5.0	7.0	14
90	101.6	111.1	5.0	7.0	14